

Traction motor data		
Type : Permanent Magnet Motor		
Curve		
Power	W	400
Battery voltage	V	48
Speed	Rpm	2000
Current	A	12
Torque	Nm	1.9
Enclosure	IP	20

Traction gear data		
Gear ratio	i	1:13.8
Max accel. and braking torque	Nm	80
Nominal wheel torque	Nm	21
Max load on vulkollan wheel	Kg	500
Max load on poliurethan wheel	Kg	
Max load on solid rubber wheel	Kg	
Brake torque	Nm	5
Lubrication		Grease

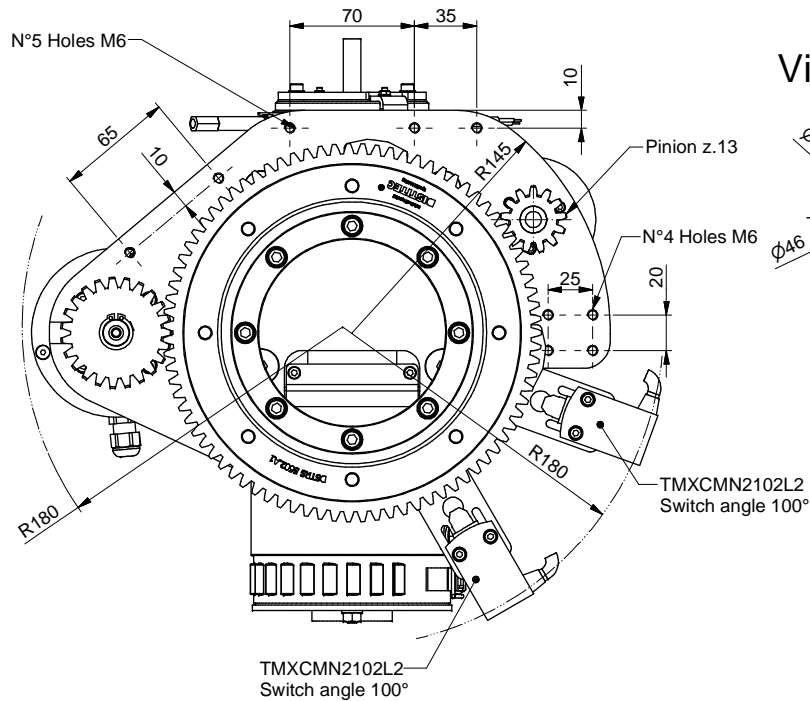

View from "A"

View from "B"

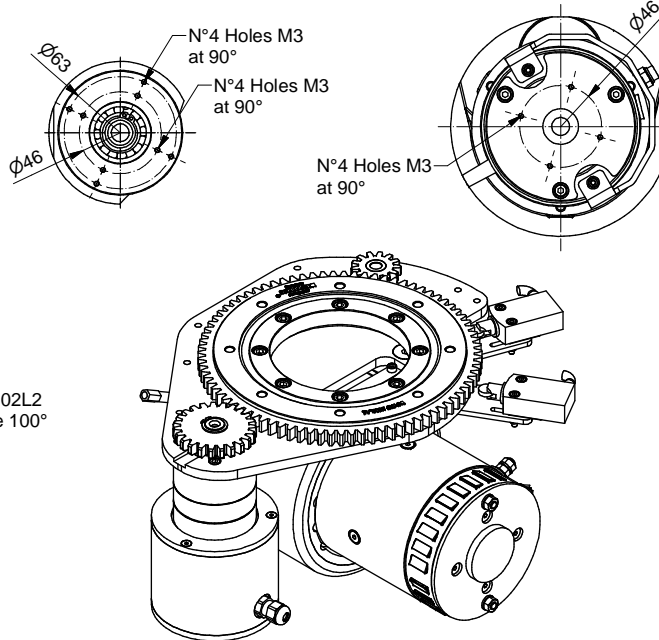

Steering gearmotor data		
Type : Permanent Magnet Motor		
Curve		
Power	W	100
Battery voltage	V	48
Motor Speed	Rpm	3000
Current	A	4
Motor torque	Nm	0.3
Gear ratio	i	1:45.56
Gear Output Torque	Nm	10.9
Enclosure	IP	44
Lubrication		Grease

Total Weight	Kg	25
---------------------	----	----

Rev.	Description	Date	Signature
C			
B			
A			

Data : 28/01/2021	Scale : 1 : 3	A3
Dis : A.Ar.		
Drawn :		