

View from C

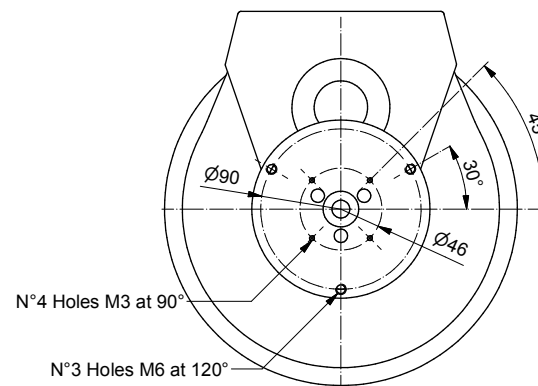

Traction motor data

Type : Permanent Magnet Motor		
Power (S2 - 60 min)	W	200
Battery voltage	V	24
Speed	Rpm	3500
Current	A	12
Torque	Nm	0.55
Enclosure	IP	20

Traction gear data

Gear ratio	i	1:21
Max accel. and braking torque	Nm	180
Nominal wheel torque	Nm	8.6
Max load on vulkollan wheel	Kg	600
Max load on poliurethan wheel	Kg	550
Max load on solid rubber wheel	Kg	400
Brake torque	Nm	
Lubrication		Grease

Steering gearmotor data

Type : Permanent Magnet Motor		
Power (S2 - 60 min)	W	
Battery voltage	V	
Motor Speed	Rpm	
Current	A	
Motor torque	Nm	
Gear ratio	i	
Gear Output Torque	Nm	
Enclosure	IP	
Lubrication		

Total Weight	Kg	35
---------------------	----	----

Data :	14/04/2017	Scala :	1 : 3	A3
Date :		Scale :		
Dis :	S.A.			
Drawn :				