

Plug AMP Automotive
Superseal 1.5
Series P2 282104-1
Thermic sensor STS1 U129

Plug AMP Automotive
Superseal 1.5
Series P4 282106-1
Encoder ES 64 PPR

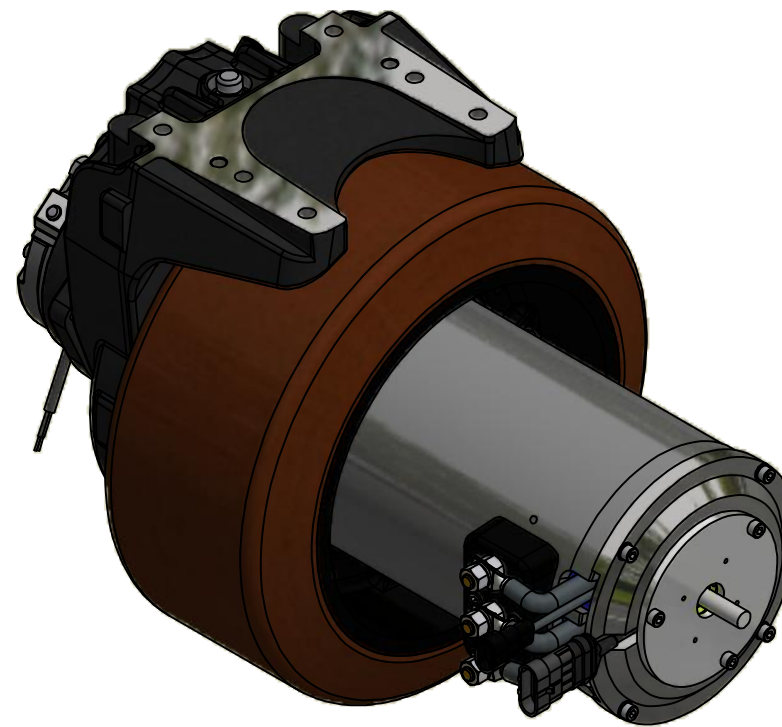

Traction motor data		
Type : AC Asynchronous		
Power (S2 - 60 min)	W	2200
Motor voltage (~3)	V	27
Battery voltage	V	48
Speed	Rpm	2500
Frequency	Hz	85
Current	A	56
Torque	Nm	8,4
Enclosure	IP	44
AC motor type	AM135 - 150	

Traction gear data		
Gear ratio	i	1:29,3
Max accel. and braking torque	Nm	600
Nominal wheel torque	Nm	209
Max load on vulkollan wheel	Kg	-
Max load on poliurethan wheel	Kg	1800
Max load on solid rubber wheel	Kg	-
Brake torque	Nm	16
Lubrication	Oil	

Total Weight	Kg	74
---------------------	----	----

Rev.	Description	Date	Signature
C			
B			
A			

Data :	04/05/2020	Scala :	1 : 5.5	A3
Date :		Scale :		
Dis :	A.A.			
Drawn :				