

Plug AMP Automotive Superseal 1.5  
Series P4 282106-1  
Encoder RT 48 PPR

Plug AMP Automotive Superseal 1.5  
Series P2 282104-1  
Thermic sensor STS1 U129

Plug AMP Automotive superseal 1.5  
Series P4 282106-1  
Encoder RT 64 PPR

Plug AMP Automotive superseal 1.5  
Series P2 282104-1  
Thermic Sensor  
STS1 U129

Brake 80V 100 Nm +  
Hand release

**Detail A**

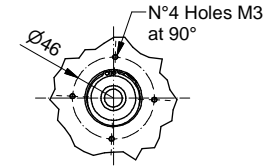

**Detail B**

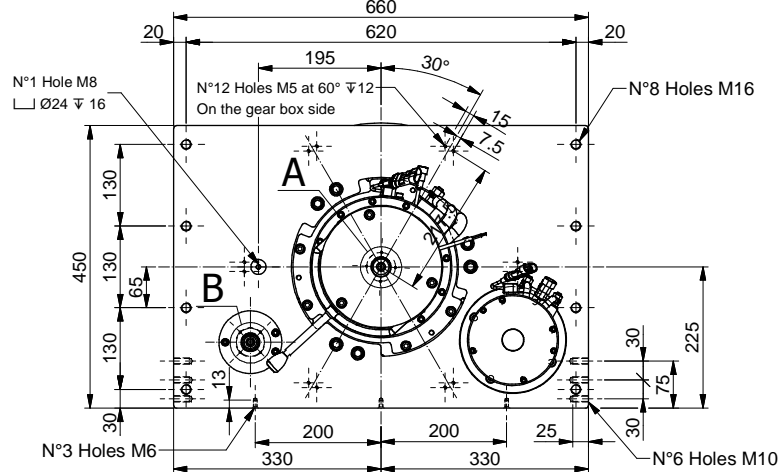
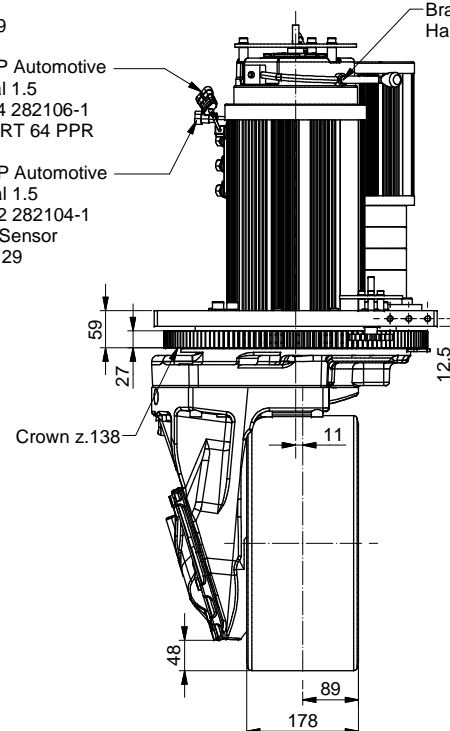
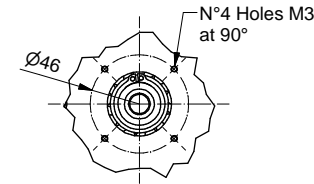

**View C**

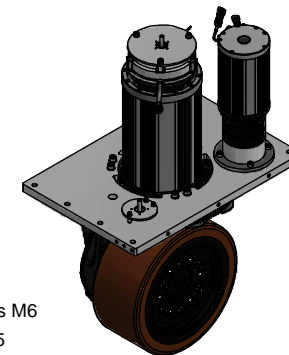
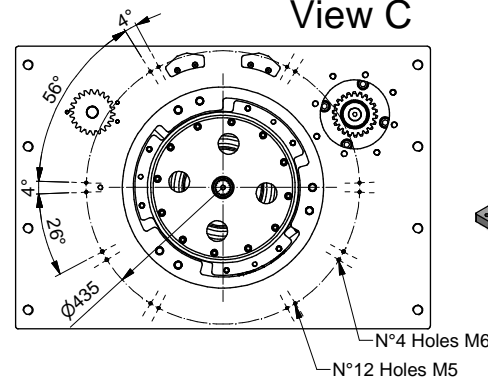

**Traction motor data**

Type : AC Asynchronous		
Power (S2 - 60 min)	W	10000
Motor voltage (~3)	V	54
Battery voltage	V	80
Speed	Rpm	1800
Frequency	Hz	60
Current	A	145
Torque	Nm	53
Enclosure	IP	44
AC motor type	AME200 - 190 - 4	

**Traction gear data**

Gear ratio	i	1:24.4
Max accel. and braking torque	Nm	2600
Nominal wheel torque	Nm	1165
Max load on vulkollan wheel	Kg	4300
Brake torque	Nm	100
Lubrication	Oil	

**Steering gearmotor data**

Type : AC Asynchronous		
Power (S2 - 60 min)	W	1400
Motor voltage (~3)	V	54
Battery voltage	V	80
Motor Speed	Rpm	3000
Frequency	Hz	100
Current	A	22
Motor torque	Nm	4.5
Gear ratio	i	1:50.89
Gear output torque	Nm	158.5
Enclosure	IP	20
Lubrication	Grease	
AC motor type	AGE125 - 100 - 4	

<b>Total Weight</b>	Kg	285
---------------------	----	-----

Data : 23/07/2019	Scale : 1:8.5	<b>A3</b>
Date : S.I.	Scale :	
Dis :		
Drawn :		